

OWNER'S MANUAL

TRC-482 CB/WEATHERADIO

Please read before using this equipment

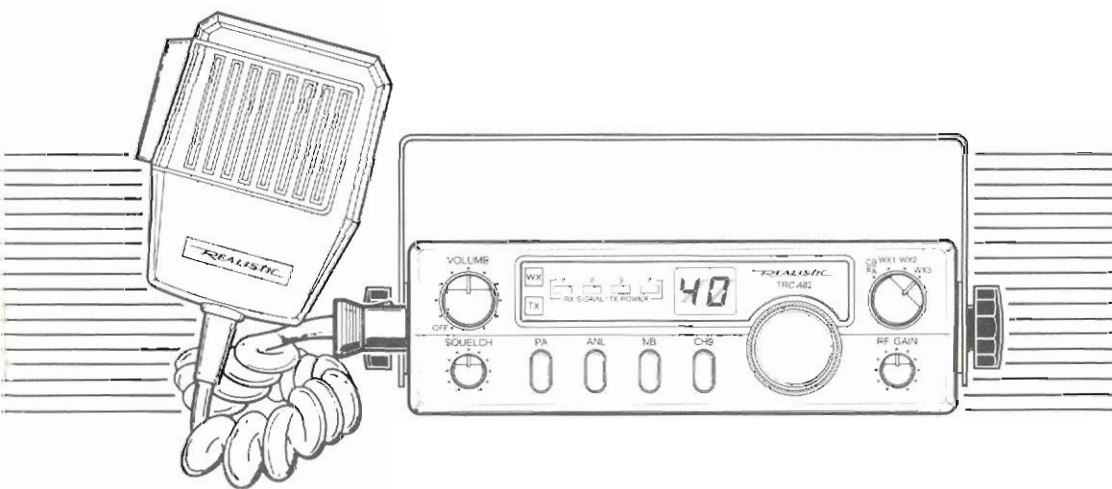

Cat. No. 21-1551

REALISTIC[®]

INTRODUCTION

FEATURES

Your Realistic TRC-482 40-CB/Weatheradio is a high performance CB that also lets you tune in to the latest weather information. You can also connect optional equipment to your CB, such as external speakers for a PA system or equipment for a base station.

This CB is perfect for recreational, business, or emergency use. You can call for help or call other people who have CBs at home, in their vehicles, or at camp sites.

Your CB has the following features:

Built-In PLL (Phase-Locked Loop) Frequency Synthesizer—uses a precise frequency reference for reliable and exact tuning.

Two Ceramic Filters—give your CB superior selectivity and freedom from adjacent-channel interference.

Hysteresis Squelch Circuit—Compensates for fading signals and eliminates signal chopping during reception.

Automatic Noise-Limiter Circuit—reduces noise caused by nearby electrical equipment such as motors or automotive ignition systems.

Digital Channel Display—lets you see the channel number you select.

RF Gain Control—lets you adjust the reception to match the strength of the received signal.

Emergency Channel 9 Switch—lets you quickly switch to channel 9 to report emergency situations.

Public Address Capability—lets you use your CB for public address with an optional PA speaker.

Universal Mounting Bracket—lets you mount your transceiver securely in place.

For your permanent records, we urge you to record your CB's serial number in the space provided below. The serial number is on the back panel of the CB.

Serial Number _____

©1991 Tandy Corporation.
All Rights Reserved.

Radio Shack and Realistic are registered trademarks used by Tandy Corporation.

CONTENTS

- Installation** 4
 - Connecting the Microphone 4
 - Mounting the CB 5
 - Installing an Antenna 6
 - Connecting Optional Speakers 7
 - Connecting Power 8
 - Using the CB as a Base Station 9
- Operation** 10
 - Receiving 10
 - Transmitting 12
 - Using the Public Address Function 13
 - Observing CB Courtesy 13
 - Using Common 10 Codes 13
 - Listening to Weather Broadcasts 14
- Maintenance** 15
- Problem Solving Guide** 16
 - Troubleshooting 16
 - Reducing Noise 17
 - Replacing the Fuse 17
- FCC Information** 18
- Specifications** 19

INSTALLATION

CONNECTING THE MICROPHONE

To mount the microphone's holder, do the following:

1. Attach the microphone holder to the CB's side, and secure it with the supplied screws and washers.

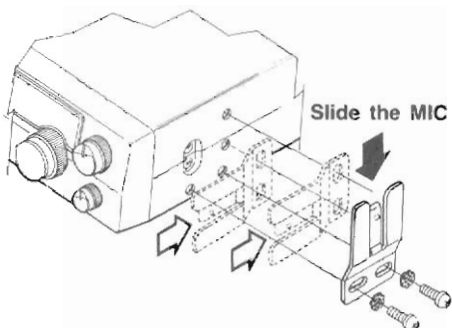

2. Press the small tab on the side of the supplied microphone's plug and insert the plug into the CB's microphone jack. Be sure the tab is aligned with the jack's notch.

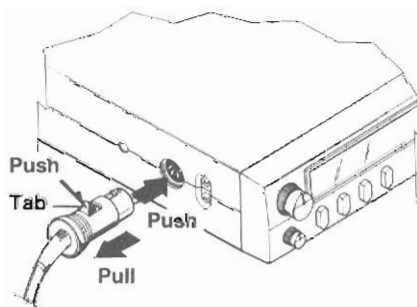

3. Slide the microphone onto the microphone holder.

Notes:

- You can connect the holder in a different position from what is illustrated.
- To disconnect the microphone cable, hold down the small tab on the side of the plug. Then, pull out the plug. Never pull on the microphone cable.

MOUNTING THE CB

The most common mounting location for this CB is under a vehicle's dashboard. When you choose a location, do the following:

- Be sure you can easily reach it.
- Keep cables clear of the vehicle's pedals or other moving parts.
- Be sure the CB is not directly in front of the heating vents.

- Place the CB so that passengers have enough leg room.
- Be sure all wires reach their connection points.

Caution: Be sure your vehicle has a 12-volt DC, negative-ground electrical system. This CB does not work with other types of systems.

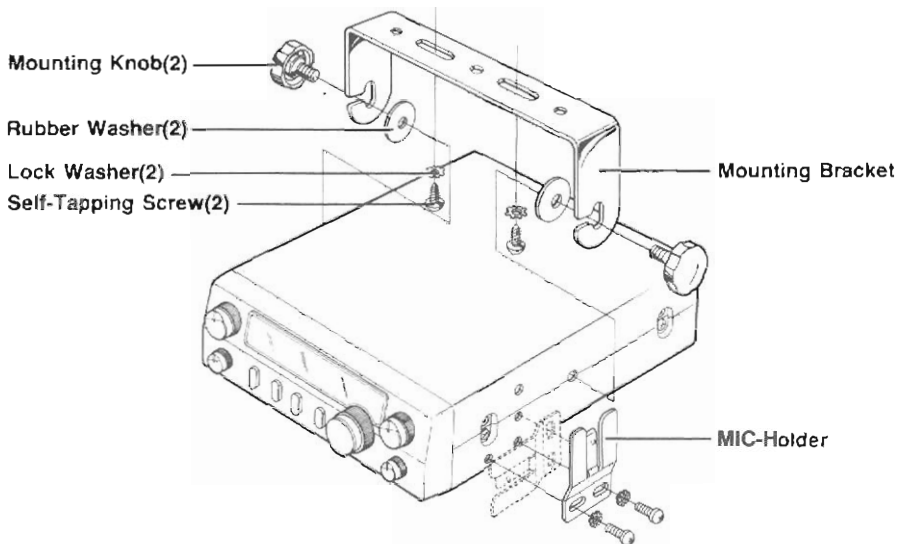

Use the supplied hardware to mount the CB as described below.

1. Using the mounting bracket as a guide, mark the positions for the screw holes.
2. In each marked location, drill a hole slightly smaller than the self-tapping screws.
3. Attach the bracket with the supplied self-tapping screws and lock washers.
4. Attach the CB to the bracket using the rubber washers and mounting knobs.

Caution: Do not drill into objects behind the mounting surface.

Caution: To prevent damage to your CB, you must connect an antenna to the CB before you operate it.

INSTALLING AN ANTENNA

There are many different types of CB antennas for mobile CBs. Each type has benefits, and you should choose the one that best meets your needs. Radio Shack stores carry a complete line of mobile CB antennas. Contact your nearest Radio Shack store for assistance.

When deciding on an antenna and its location, also consider the following:

- Mount the antenna as high as possible on the vehicle.
- Mount the antenna as far as possible from sources of electrical noise (ignition system, gauges, etc.) and keep the antenna cable away from these noise sources.
- For best performance, the antenna should be vertical while you operate the CB.

Some popular types of antennas and how to mount them are described below.

Gutter or Trunk-Lid Antenna—this antenna clamps onto your vehicle, so you do not have to drill holes to mount it. The trunk-lid antenna's coverage patterns are slightly directional because the patterns move to the front of and away from the side of the vehicle. The gutter antenna has a slightly better range than the trunk-lid antenna because you usually mount it higher on the vehicle.



Magnetic Antenna—a strong magnet attaches this antenna to your vehicle. You can attach the antenna to any flat metal surface. This antenna is great for temporary installations, but you can also use it for permanent installation. Its greatest benefit is that you can mount it at the center of the vehicle's roof for best performance, without drilling holes.



Roof Antenna—the roof antenna radiates the signal equally in all directions and provides the best range because it is usually at the highest point on the vehicle. However, you must drill a hole in the vehicle's roof to mount this antenna.

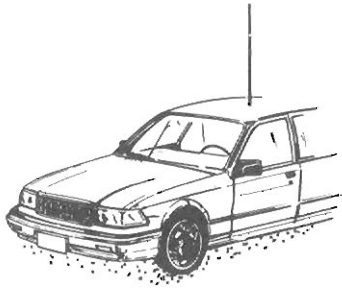

Bumper Antenna—this type of antenna is usually a 102-inch, $\frac{1}{2}$ -wave antenna that clamps onto your bumper. Its signal pattern is slightly directional because the pattern moves to the front of and away from the side of the vehicle. Because of its length, this type of antenna usually provides excellent performance, but the length can be a problem in low-clearance areas.



Once you choose an antenna, follow the mounting instructions for the antenna. Then, route the cable to the CB and connect the cable to the **ANTENNA** jack on the back of the CB. Observe the following precautions when routing the antenna cable:

- Avoid sharp edges or moving parts that might damage the cable.

- Do not run the cable next to power cables or other CB antenna cables.
- Do not run the cable through the engine compartment or other areas that produce extreme heat.

CONNECTING OPTIONAL SPEAKERS

You can connect your CB to an external or public-address speaker.

External CB Speaker

To connect an external CB speaker to the CB, use an 8-ohm speaker, capable of handling 3- to 10-watts of power (such as Radio Shack's Cat. No. 21-549). The speaker's cable must have an $\frac{1}{8}$ -inch plug. Insert the speaker cable's plug into the **EXT** speaker jack on the back of the CB. The CB's internal speaker disconnects.

PA Speaker

To use the CB's public address function, connect a cable with an $\frac{1}{8}$ -inch plug to the **PA** speaker jack on the back of the CB and to an 8-ohm, 5-watt or more speaker, such as Cat. No. 40-1236. See "Using the Public Address Function."

CONNECTING POWER

You can power this CB from your vehicle's battery or from AC power. See "Using the CB as a Base Station" for AC power connection.

Follow these steps to power the CB from your vehicle's battery.

1. Connect the black BATT (-) wire to your vehicle battery's negative (-)

terminal or to a metal part of the vehicle's frame.

2. Connect the red wire, with in-line fuse, to an accessory terminal or source of voltage that turns on and off with the ignition switch. This wire supplies power to operate your CB.

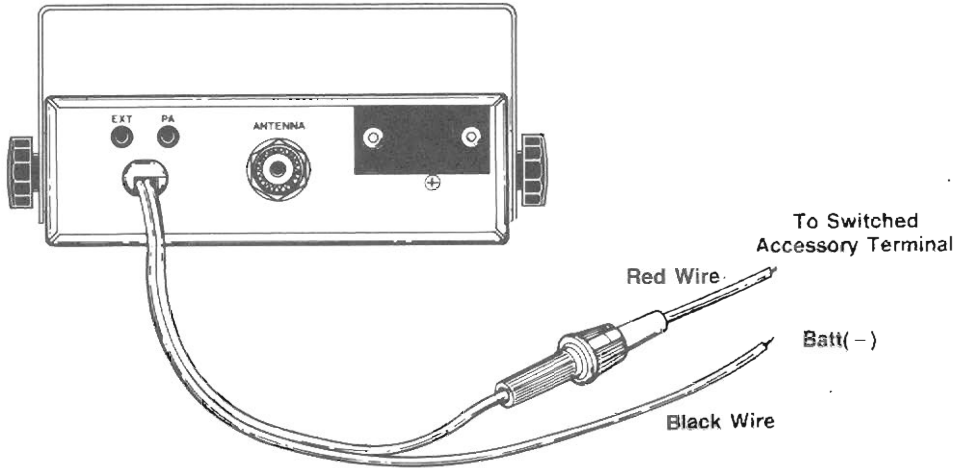

USING THE CB AS A BASE STATION

Although we designed your CB for mobile use, you can also use it as a base station. For this type of installation, you need the following:

- 12-volt DC power supply (such as Cat. No. 22-120)
- Base station antenna (such as Cat. No. 21-967).

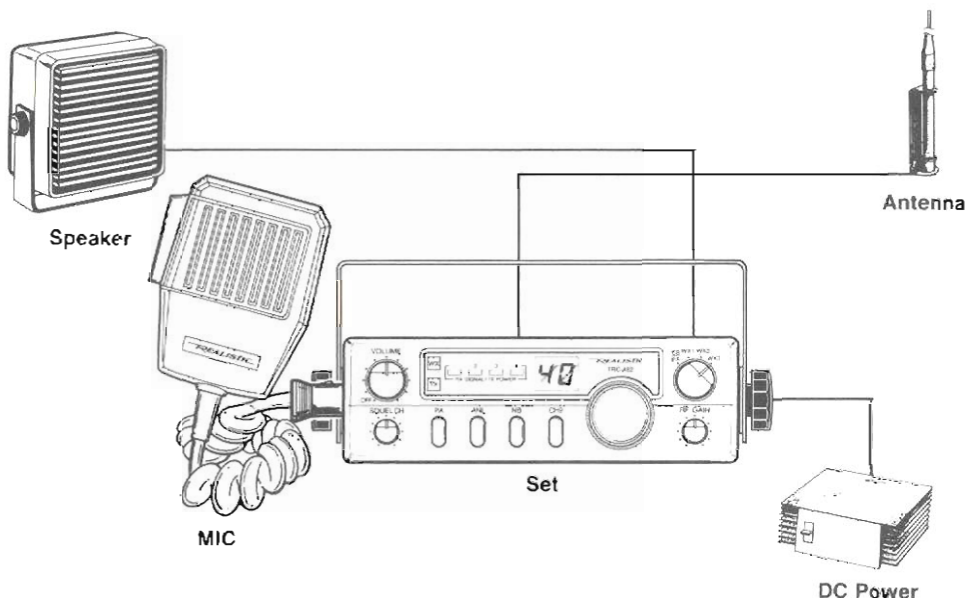

To use the CB as a base station, do the following:

1. Mount the antenna as described in its instruction manual.
 2. Connect the antenna to the **ANTENNA** jack on the back of the CB.
 3. Connect the red power wire to the DC power supply's positive (+) terminal.
 4. Connect the black wire to the DC power supply's negative (-) terminal.
 5. Connect the DC power supply to a standard 120V AC outlet.
- Warning:** Use extreme caution when you install or remove a base-station CB antenna. If the antenna starts to fall, let it go. It could contact overhead power lines. If the antenna touches the power line, contact with the antenna, mast, cable, or guy wires can cause electrocution and death. Call the power company to remove the antenna. Do not attempt to do so yourself.

OPERATION

RECEIVING

You can use this CB in three different ways:

- Use it as a CB in your vehicle.
- Use it as a base station at home with an external speaker.

- Use it as a public address system with a PA speaker mounted on the top of your vehicle.

Caution: Do not attempt to use your CB if you have not connected it to an antenna.

Follow these steps to receive transmissions:

1. Set the function selector to **CB/PA**, and be sure **PA** is out.

- Turn **OFF/VOLUME** to the right until the CB clicks on.
- Turn **SQUELCH** counterclockwise so that you can hear background noise.

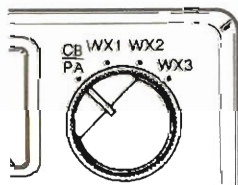

2. Adjust the **VOLUME** to a comfortable listening level.

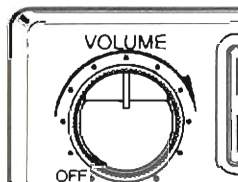

3. To select a channel:

- Press **CH9** so that it is out for any channels other than Channel 9, and continue to Step 4.
- Press **CH9** so that it is in to select Channel 9. **CHANNEL** does not affect the channel while **CH9** is in. When you press **CH9** so that it is out, the CB returns to the channel you have selected with channel.

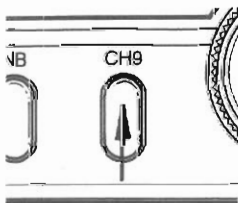

4. To select a channel, turn **CHANNEL**, on the CB's panel.

The **RX SIGNAL** strength meter indicates the strength of any received signals.

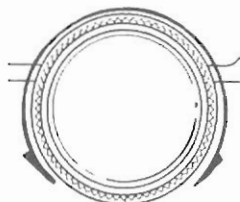

5. Slowly turn **SQUELCH** to the right until the hiss of background noise disappears.

If you turn **SQUELCH** all the way to the right, you might not hear weak signals. To receive very weak signals, turn **SQUELCH** all the way to the left. You hear noise between transmissions, but you also hear weak signals.

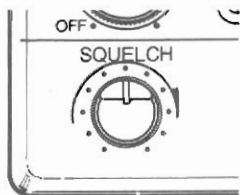

6. Adjust **RF GAIN** for the best signal.

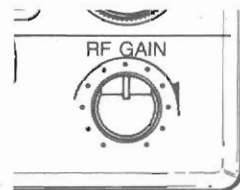

7. If you hear low-level impulse-type noise, press in **ANL** to turn on the automatic noise limiter circuit.

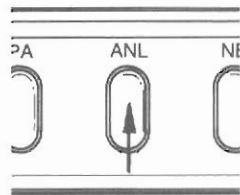

8. If you hear high-frequency noise, such as ignition noise, press in **NB** to turn on the noise blanker circuit.

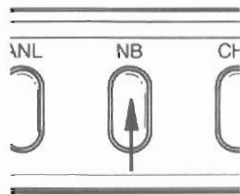

TRANSMITTING

Complete the steps in "Receiving" before you try to transmit.

1. Rotate **CHANNEL** to select the channel you want.

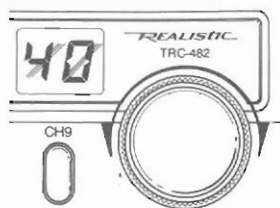

2. Hold the microphone 2 or 3 inches from your mouth, hold down the talk button on the microphone, and speak in a normal voice.

Notes:

- The **TX POWER** meter indicates your output power when you hold down the talk button.
- Speaking loudly into the microphone does not increase your signal, but might distort your transmission.



3. Release the talk button to receive transmissions.

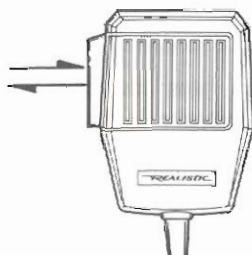

4. To end the CB operation, turn **OFF/VOLUME** to the left until you hear a click. The display and indicator turn off.

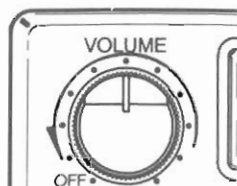

USING THE PUBLIC ADDRESS FUNCTION

To use the public address function, connect the speaker to the CB as described in "Connecting Optional Speakers." (You can mount a **PA** speaker on the top of your vehicle.) Then, do the following:

1. Set the function selector to **CB/PA** and press in **PA**.
2. Hold down the microphone's talk button and speak in a normal voice.
3. Adjust **VOLUME** for a suitable public address level.

Notes:

- When you press in **PA**, your CB disconnects the internal and external CB speaker.
- To prevent feedback or high-pitched sounds, keep the microphone facing away from the **PA** speaker and hold the microphone as far away from the CB as possible.

OBSERVING CB COURTESY

Remember these hints when using your CB:

- Wait for a pause in transmission before asking for a break.
- If you do not receive an answer after two calls to a station, sign off and let others use the channel. Try again later.
- Do not hold down the talk button (dead key) when you are not talking.
- Help callers with directions, road conditions, or other requested information.

USING COMMON 10 CODES

Citizens band operators have largely adopted the 10-codes for standard questions and answers. These codes permit faster and better communications in noisy areas. The following table lists some common codes and their meanings.

Code	Meaning
10-1	Receiving poorly
10-2	Receiving well
10-3	Stop transmitting
10-4	OK-understood
10-7	Out of service
10-9	Repeat
10-10	Standing by
10-13	Advise road and weather conditions
10-20	What is your location?
10-33	Emergency traffic
10-36	What is the correct time?
10-41	Switch to Channel xx
10-62	Cannot understand

LISTENING TO WEATHER BROADCASTS

The National Oceanographic and Atmospheric Administration (NOAA) broadcasts continuous transmissions on three frequencies to provide current weather conditions and forecasts. To hear a weather broadcast, set the function selector to **WX1**, **WX2**, or **WX3**. Each channel has the same broadcast, but you might be able to receive better on one of the channels.

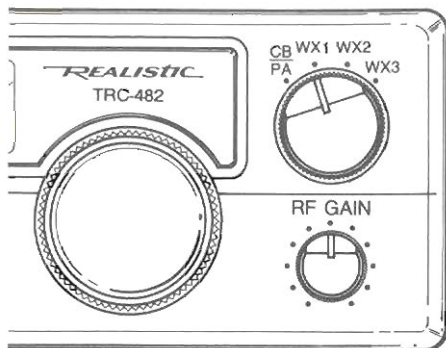

MAINTENANCE

Your TRC-482 is an example of superior design and craftsmanship. The following suggestions will help you care for your CB so that you can enjoy it for years.

Keep the CB dry. If it does get wet, wipe it dry immediately. Liquids might contain minerals that can corrode the electronic circuits.



Handle the CB gently and carefully. Dropping it can damage circuit boards and cases, and can cause the CB to work improperly.



Keep the CB away from dust and dirt, which can cause premature wear of parts.



Wipe the CB with a dampened cloth occasionally to keep it looking new. Do not use harsh chemicals, cleaning solvents, or strong detergents to clean the CB.



Modifying or tampering with the CB's internal components can cause a malfunction and invalidate the CB's warranty and void your FCC authorization to operate it. If your CB is not performing as it should, take it to your local Radio Shack store. Our personnel can assist you and arrange for service if needed.

PROBLEM SOLVING GUIDE

TROUBLESHOOTING

If at any time you suspect that your CB is not working as it should, refer to the following chart to see if you can eliminate the problem.

If the problem persists, take the CB to your local Radio Shack store. Do not attempt repairs or adjustments yourself.

SYMPTOM	CHECK & SOLUTION
Trouble with reception	Check to see if the CB is turned on. Be sure the function selector is set to CB/PA . Adjust the volume. Turn SQUELCH to the left. Secure the microphone connection.
Trouble with transmission	Secure the antenna connector. Extend the antenna to its full length. Clean and tighten all connectors. Be sure you are pressing the talk button all the way in. Firmly press the microphone connector into the jack.
No channel selection	Be sure the function selector is set to CB/PA . Make sure CH9 is out.
CB does not work at all	Secure the power connection. Check the fuse and replace it, if necessary.

REDUCING NOISE

Because your CB is exceptionally quiet, any noise you hear is probably from an external source in your vehicle, for example, the ignition, another CB, or spark plugs.

To solve the problem you must find the source of the noise. You can determine the source of the noise by turning off the engine and operating the transceiver with the ignition set to ACC. If most of the noise goes away, the problem, is in your vehicle's ignition or electrical system.

Otherwise, the problem is in your CB or is being caused by other electrical equipment. Here are a few hints to help you reduce or eliminate such noise:

- Make all CB power and antenna wires as short as possible.
- Route the power wires away from antenna wires.
- Be sure that the ground connection (black wire) is secure.
- Replace old ignition wires with new, high-voltage, noise-suppression wires.
- Install noise suppressors on your spark plugs, or install new spark plugs that have built-in suppressors. If problems persist, check your regulator, alternator/generator, and gauges. You can reduce the noise from these sources by using bypass capacitors at the various output voltage points. Your local Radio Shack store has a wide selection of noise-suppression accessories.

REPLACING THE FUSE

A 2-amp fuse protects your CB from power surges and short circuits.

To replace the fuse, do the following:

1. Hold the fuse holder by both ends.
2. Push the fuse holder together.
3. While pushing the holder inward, turn the thick end and then release it. The fuse holder opens.

If the fuse has blown, replace it with one of same type and rating—2-amp fuse (Cat. No. 270-1275).

FCC INFORMATION

The Federal Communications Commission (FCC) does not require you to have a license to operate this CB. However, the FCC does require you to read and know Part 95 of FCC Rules. These rules apply to the operation of a Class D CB transceiver. We have provided a copy of these regulations with your CB.

Warning: Do not open your CB to make any internal adjustments. Any internal adjustments can be made only by, or under the direct supervision of, a person holding an FCC 1st or 2nd class radio operator's license.

Internal adjustments and/or modifications can lead to illegal operation as defined by FCC Rules, Part 95. Such illegal operation can lead to very serious consequences.

To be safe and sure:

- Never open your CB's case.
- Never modify your CB.

Your CB might cause TV or radio interference even when it is operating properly. To determine whether your CB is causing the interference, turn off your CB. If the interference goes away, your CB is causing the interference. Try to eliminate the interference by:

- Moving your CB away from the receiver
- Contacting your local Radio Shack store for help

If you cannot eliminate the interference, the FCC requires that you stop using your CB.

SPECIFICATIONS

RECEIVER

Frequency Coverage	: All 40 CB Channels (Class D) 26.965 to 27.405 MHz
Sensitivity	: 0.7 μ V or better for 10 dB (S + N)/N
Adjacent Channel Rejection	: 60 dB (at 10 kHz)
Audio Output	: 4 Watts (Maximum)
Frequency Response	: 450-2500 Hz
Cross Modulation	: 50 dB
Squelch	: Adjustable from 0.6 μ V to 1 mV

TRANSMITTER

Frequency Coverage	: All 40 CB Channels (Class D) 26.965 to 27.405 MHz
Output Power	: 4.0 Watts (Maximum)
Type of Modulation	: AM Double-Sideband, Full Carrier
Modulation Capability	: +/ - 90%
Spurious Emission	: Less than -65 dB
Frequency Tolerance	: 0.002%
Antenna Impedance	: 50 Ohm
Current Drain (13.8-Volt Supply)	: 1 Amp with No Modulation 1.5 Amps with Full Modulation

PUBLIC ADDRESS

Output Power	: 4 Watts (Maximum)
Current Drain (at maximum power)	: 1.2 Amps
Power Requirements	: 12-16 Volts DC, Negative Ground
Dimensions	: 11 ⁴ / ₁₆ × 5 ¹ / ₁₆ × 7 ¹⁵ / ₁₆ Inches (H × W × D) (47 × 150 × 202 mm)
Weight	: 2lbs 4.5 oz (1 Kg)

WEATHERADIO

Frequency Coverage	: 162.4(WX1), 162.475(WX2), 162.55(WX3)
20 dB Quieting	: 1.5 μ V or Better for 20 dB (S + N)

RADIO SHACK LIMITED WARRANTY

This product is warranted against defects for 90 days from date of purchase from Radio Shack company-owned stores and authorized Radio Shack franchisees and dealers. Within this period, we will repair it without charge for parts and labor. Simply **bring your Radio Shack sales slip** as proof of purchase date to any Radio Shack store. Warranty does not cover transportation costs. Nor does it cover a product subjected to misuse or accidental damage.

EXCEPT AS PROVIDED HEREIN, RADIO SHACK MAKES NO WARRANTIES, EXPRESS OR IMPLIED, INCLUDING WARRANTIES OF MERCHANTABILITY AND FITNESS FOR A PARTICULAR PURPOSE. Some states do not permit limitation or exclusion of implied warranties; therefore, the aforesaid limitation(s) or exclusion(s) may not apply to the purchaser.

This warranty gives you specific legal rights and you may also have other rights which vary from state to state.

We Service What We Sell

RADIO SHACK
A Division of Tandy Corporation
Fort Worth, Texas 76102